



NEZ Technical regulations 2019

1. Competition vehicles

Eligible models must be considered a “production vehicle” and have had a minimum build run of 600 units in each model year.

Eligible body styles include: coupe, sedan, convertible or wagon and have no more than 5 doors. Vehicles must maintain the original OEM steel unibody and/or steel frame structure between the OEM front and rear suspension mounting points. No trucks or SUVs will be allowed.

Vehicles that do not meet the above eligibility criteria must petition for approval from Drift working group.

2. Chassis

2.1 Chassis modifications

- A. The original OEM floorpan, frame and or unibody must remain unmodified between the vertical planes created by the original forward most and rear ward most suspension point or subframe mounting point.
- B. Unibody or chassis may be stich or seam welded.
- C. Plating of chassis is prohibited.
- D. Front suspension examples are in Figure 1 and 2.
- E. Rear suspension examples are in Figures 3 and 4.

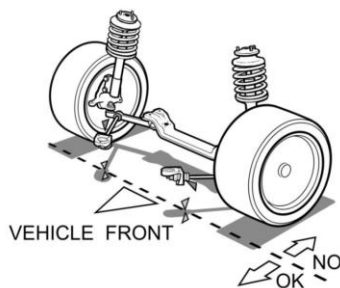

Figure 1

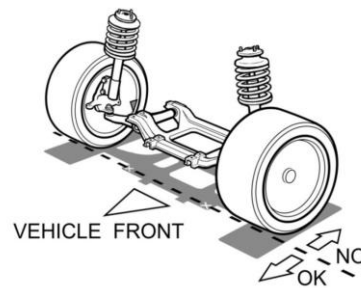

Figure 2

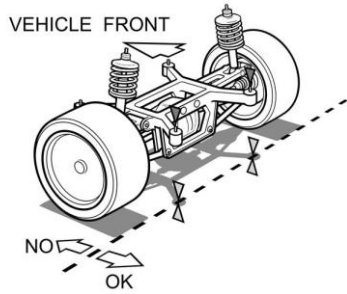

Figure 3

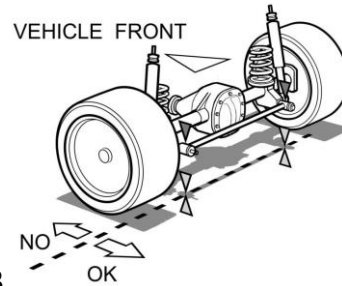

Figure 4

- F. The original OEM floorpan, frame and or unibody must remain unmodified between the horizontal planes created by the original floorpan at the lowest horizontal plane to the roof at its highest horizontal plane. With the exception of transmission tunnel and firewall dimensions listed below and Fuel cell rule.
- G. Items in the unmodified zone that are allowed to be removed can include original rear window parcel shelf, tabs or mounts for unused OEM steering columns, unused OEM windshield wiper mounts, and the exterior roof panel can be replaced with a composite panel.
- H. Rear suspension tower cross-members located at the top of the rear suspension towers may be removed from the unibody interior only if a suitable replacement structure of equivalent strength is installed.
- I. No part of the engine casing may cross the vertical threshold of the original firewall into the transmission tunnel.
- J. No other modifications may be made to the vehicle chassis, frame, or unibody.
- K. Any holes in the firewall must be of the minimum size for the passage of controls and wires, and must be completely sealed to prevent the passage of fluids or flames from the engine compartment to the drivers compartment.

2.1.1 Firewall and transmission tunnel -

- A. Modifications of the stock, OEM firewall and transmission tunnel are in Figure 5:

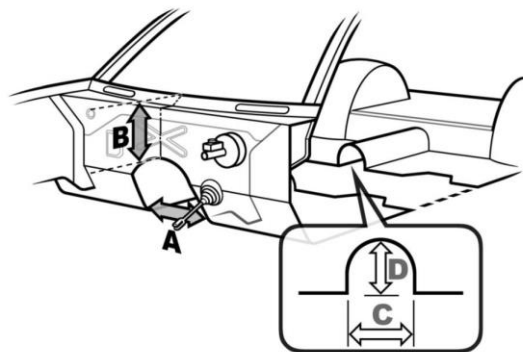

Figure 5

- B. Dimension A: Tunnel Width may be no wider than 45,70cm

- C. Dimension B: Minimum dimension of 25,4cm between the bottom of the windshield and the top of the transmission tunnel.
- D. Dimension C: Modifications to drive shaft tunnels behind the engine firewall vertical plane should not exceed an overall width of 25,4cm.
- E. Dimension D: Modifications to drive shaft tunnels behind the engine firewall vertical plane should not exceed an overall width of 25,4cm.
- F. Taper Length from the firewall to the end of the transmission tunnel into the beginning of the drive shaft hump may be no longer than 91,45cm.

3. ROLLAGE

- A. The fitting of a safety cage is compulsory.
- B. Cars made from 2018 –must be in accordance with Annex "J" 253 FIA ART 8.
- C. For safety cages of cars homologated before 01.01.2017, refer to Articles 253-8 of the 2016 Appendix J.
- D. Any cage which is homologated by an ASN must be identified by means of an identification plate affixed to it by the manufacturer this identification plate must be neither copied nor moved (i.e. embedded, engraved, metallic plate). The identification plate must bear the name of the manufacturer, the homologation or certification number of the ASN homologation formor certificate and the individual series number of the manufacturer. An authentic copy of the homologation document or certificate bearing the same numbers, approved by the ASN and signed by qualified technicians representing the manufacturer, must be presented to the competition's scrutineers.
- E. Allowed only seam welded rollcages.

3.1 Padding

- A. Padding must meet spec FIA 8857-2001.
- B. Padding is required anywhere driver helmet may come in contact with the roll cage and along the base of the driver's side A-pillar bar and box if applicable.

4. Bumpers

- A. All vehicles must be equipped with safe front and rear bumpers.
- B. Bumpers at minimum must span the width of the front and rear frame rails.
- C. Bumper bars must remain in the confines of the body lines and body work, without additional covers or body work extensions in order to do so.
- D. Bumpers must be attached to the vehicle by means of 2, for example 8 mm welded bolts, on the side with a minimum hardness class 8.8, in order to prevent the bumper from falling off the vehicle .
- E. The construction of the bumper must not protrude beyond the outline of the car and must be completely under the outer bumper .

5. Suspension and brakes

5.1 Front Suspension

A. Free modification

5.2 Steering

- A. Modifications of steering components (steering rack, tie rods, etc) are free.
- B. This includes mounting the rack to the front subframe.
- C. The locking system of the anti-theft steering lock may be rendered inoperative.
- D. The column adjusting system must be locked and must be operated only with tools.

5.3 Rear suspension live axle

A. Free modifications

5.4 Rear suspension – independent

A. Free modifications

5.5 Brakes

- A. The primary brake system must operate all 4 wheels.
- B. Dual master cylinders pedal assemblies are allowed.
- C. Driver adjustable brake bias is allowed.
- D. Secondary hydraulic e-brake systems are allowed as a fully separate system or as a pass through system.
- E. Carbon fiber, carbon ceramic, and carbon variant brakes or rotors are not allowed.
- F. Brake pedal box reservoirs must be outside the cockpit.
- G. Handbrake reservoir should be closed one.
- H. Brake shut-off valve is prohibited.

5.6 Wheels

- A. The use of additional locks between the rim and the tire is forbidden.
- B. The maximum permissible tire width used on the rear axle wheels is 285mm.

6. Drivetrain

6.1 Engine

- A. Engine substitutions and modifications are free, but may only run on gasoline, diesel, and ethanol blends. All other fuels require written approval from the COMPETITION DIRECTOR.
- B. All fluid systems must be free of leaks.

6.2 Cooling system

- A. Cooling system modifications are free but must be fully closed and free of leaks.
- B. Automatic water sprayers will be allowed during competition, but must not be leaking on the track, starting line, or grid area.
- C. If cooling system lines are routed in the driver's compartment or a trunk area that is open to the driver, they must be separated from the driver by a crushable metal enclosure made of steel, aluminum or composite material. The floor of the enclosure must be designed to prevent accumulation of fluids.

- D. Cooling systems shall be filled with water only. Coolant Additives such as NEO “Keep Cool” and Redline “Water Wetter” are allowed.

6.3 Oil system

- A. Oil system modifications are free but must be fully closed and free of leaks.
- B. If the oil tank is located in the driver’s compartment area, or a trunk area that is open to the driver, it must be separated from the driver by a metal enclosure made up steel or aluminum.
- C. The floor of the enclosure must be designed to prevent accumulation of fluids.

6.4 Fuel System

- A. The fuel system design is free, but engines may only run on gasoline, diesel, and ethanol blends. Cars running bioethanol E85 should be with equipped with E85 sticker on it.

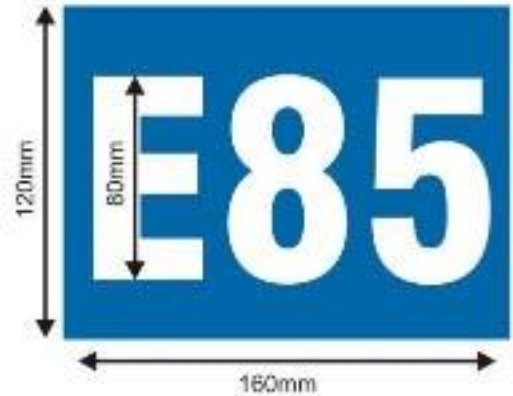

- B. Safety Fuel cells are required for all vehicles with a relocated fuel tank. FT3-1999, FT3.5-1999 or FT5-1999 and SFI 28.1 are accepted. They can be used with ended homologation term. **Cars made until 2018 season, can use self made tanks.**
- C. The use of safety foam in FT3-1999, FT3.5-1999 or FT5-1999 tanks is recommended.
- D. Safety fuel cells shall consist of a bladder enclosed in a metal container.
- E. If the factory fuel tank is retained it must be mounted in the factory location, and in the factory manner.
- F. Fuel tank/cell must be separated and completely sealed to prevent the passage of fluids or flames from entering the driver’s compartment by a permanently mounted steel or aluminum bulkhead. The bulkhead in a hatchback vehicle must be affixed to the chassis and no movable structure or panel such as the hatch will be allowed as part of the bulkhead. Fuel cells may be installed in the interior of the vehicle, preferably within the confines of the roll cage structure.
- G. The floor pan may be modified to fit a fuel cell.
- H. Fuel cells must have a flapper valve installed to prevent spillage in the event of a roll over.
- I. Fuel System must not leak on the track, starting line, or grid area.

4.4.2 Fuel lines

- A. Fuel lines and fittings according FIA appendix J 253 Art 3.
- B. All the fuel pumps must only operate when the engine is running, except during the starting process.

4.5 Exhaust system

- A. Exhausts are free to exit from the front bumper, and rear bumper. They must be adequately silenced and not be louder than 100dB(A) at 4500rpm.
- B. Vehicles must have optional noise bungs which can be securely installed to comply with additional noise restrictions at each venue. You MUST have options to silence your car at all venues .
- C. If exhaust ends in engine front, cross should be installed (welded into it).
- D. External wastegates recommended to route back in exhaust system.

4.6 Starter

- A. All vehicles must be equipped with an on-board starter and power supply which must be in working order at all times.

4.7 Transmission

- A. All vehicles must be equipped with a functioning reverse gear.
- B. Transmission and/or final drive modifications are free, but only the rear wheels may propel the vehicle.

4.8 Driveshaft

- A. All vehicles must have a driveshaft retaining loop mounted within 15 cm of the forward most universal joint and be securely attached to a unibody or frame structure as in Figure 9.
- B. The driveshaft loop may be made of minimum 6 x 50mm wide steel strap or 22 x 1,5mm steel tubing and be securely mounted in case of universal joint failure.

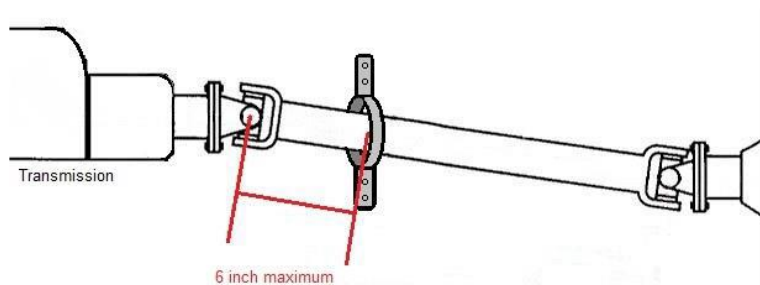
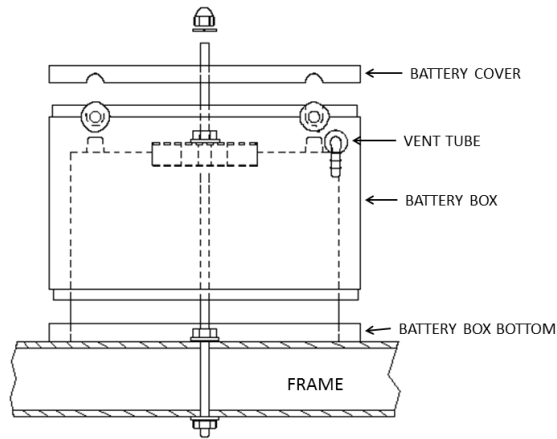

Figure 9

7. Electrical system

7.1 Battery

- A. The battery must be securely mounted and the positive terminal completely insulated to avoid contact with any other metal parts.
- B. Batteries may be relocated.
- C. Relocated batteries must be fastened to the frame or unibody with a minimum of two M10 diameter bolts.
- D. Plastic hold down brackets and J bolts or hooks are prohibited.
- E. If the battery is located in the driver's compartment, it must be in a sealed box bolted with the battery fastened inside the box securely bolted to the unibody/ chassis and properly vented and drained. It can be located only behind driver/passenger seat. From 2018 only dry battery can be used inside driver's compartment.



(2) 3/8" THREADED RODS TO PASS THROUGH BATTERY BOX AND HOLDDOWN TO SECURE THE BATTERY TO THE VEHICLE'S FRAME

7.2 Master Cutoff

- A. The car must be equipped with a general circuit breaker. The general circuit breaker must cut allelectrical circuits (battery, alternator or dynamo, lights, hooters, ignition, electrical controls, etc.) and must also stop the engine. It must be installed according to the specifications listed in the Appendix J– Art. 253, clause 13 of FIA technical regulations.

8. Body exterior and interior

8.1 Body panels

- A. Vehicles must maintain the look and feel.
- B. Panels must be clean, free of damage and presentable for competition.
- C. All bodywork must be painted or covered and securely attached to the vehicle.
- D. Aftermarket body panels, front and/or rear fascias, side skirts and wings are permitted.
- E. Over fenders are permitted.
- F. All aftermarket panels and aerodynamic devices must be securely fastened to the vehicle.

8.2 Doors

- A. Doors must be mounted to the chassis with unmodified factory hinges.
- B. Doors must use the factory latch mechanism
- C. The inside and outside door latch/ lock operating mechanism must be functional and readily accessible for the driver to exit the vehicle.
- D. Composite material doors can be used.

8.3 Windshield

- A. Windshields must be OEM glass or Lexan/polycarbonate replacement.
- B. Lexan/polycarbonate windshields must be a minimum thickness of 5mm
- C. Lexan/polycarbonate windshields must be securely mounted and have a vertical brace which is securely mounted down the center of the opening on inside the vehicle.
- D. Windshields must be clear, use of tint is prohibited.

8.4 Windows and window restraints

- A. Door, quarter and rear window must be OEM glass or clear/polycarbonate with minimum thickness of 3mm and securely bolted in place.
- B. Side windows shall have a window net, OEM glass, or a piece of Lexan/polycarbonate in place of both front window openings whenever the vehicle is on-track.
- C. Side windows and rear windows, use of tint or wrap is prohibited.
- D. Competitors may choose to use arm restraints in lieu of side windows or a window net.
- E. Competitors with convertible vehicles must use arm restraints.
- F. The use of transparent and colourless anti-shatter films (maximum thickness : 100 microns) is compulsory on side and rear windows, unless they are in polycarbonate.

8.5 Wipers

- A. Vehicles must have a functioning windshield wiper.

8.6 Mirrors

- A. Two external, rear-facing mirrors are required, and must be positioned so that the driver can see objects along both sides of the vehicle.
- B. OEM mounting position are encouraged.
- C. Cameras may be used instead of mirrors.

8.7 Hood Pins

- A. At least two additional safety fasteners must be fitted for each of the bonnet and boot lids.
- B. The original locking mechanisms must be rendered inoperative or removed.

8.8 Towing apparatus

Must be equipped front and rear as follows:

- A. Load Rating of not less than the gross vehicle weight.
- B. Minimum internal hole diameter of 50mm.
- C. Colored in a contrasting color to the surrounding body work.
- D. If not clearly visible must that their position clearly indicated by the word "TOW" or an arrow in a contrasting body color.
- E. Nevar izvirzieties arpus kuzava

8.9 Lights

6.9.1

- A. Aftermarket products should be oem look.
- B. Brake lights and tail lights may only be red, tinting is prohibited.
- C. Rear external lights, may be removed, provided that any resultant openings in the bodywork are covered. Covers must conform to the original general silhouette. LED strips can be used instead of bulbs.

6.9.2 LED

- A. Extra brake light, LED type. These lights as LED strips with a minimum length of 50 cm each, must be mounted on the roof edges just above the front and rear windows,

centrally in the axis of the car. The LED strip above the windscreen must not collide with the official Organizer's banner nor may it be covered by it.

B. Light strips must be connected to the existing brake light circuit.

8.10 Interior

A. The interior of the vehicle must be clean and professional in appearance.

B. All non-essential and/or loose items must be removed.

C. All carpeting and/or sound deadening material must be removed.

8.11 Dashboard

A. The dashboard must be either stock or fiberglass etc. stock appearing replacement.

8.12 Gauges

A. It's prohibited to use mechanical gauges in drivers compartment (oil, fuel, water).

9. Drivers safety equipment

9.1 Helmet

According to FIA technical list N.25 N.33 N.49

A. All occupants must wear a safety helmet during on-track sessions.

B. Helmet chin straps must be buckled or fastened while on course.

C. Cameras may not be mounted to competitor's helmets.

D. Use of FHR systems are mandatory.

9.2 Driving suit

A. One-piece driving suits are required and must be made of fire-resistant material and certified to FIA 2000 specs or higher, which effectively covers the body, including neck, ankles and wrists. Multi-layer driving suits are recommended.

B. Gloves, shoes, and socks are required and must be fire-resistant material and certified to FIA 8856-2000 specs.

C. Articles must be free of holes, tears or other openings except those made by the manufacturer of the equipment.

D. Fire-resistant underwear is recommended. From 2020 Mandatory.

9.3 Seats

A. All vehicles must have at least two seats, one for the driver, and one for a passenger. – japielabo, ka blakus nav obligats.

B. All the occupants' seats must be homologated by the FIA (8855-1999or 8862-2009 standards), and not modified.

C. The usable life of an FIA homologated seat is 5+5 years from the date of manufacture indicated on the seat label.

D. The homologation labels must be visible.

9.4 Seat support – according to FIA Appendix J – ART 16.

A. Seat supports shall be of the type listed on FIA technical list No.12 (lateral, bottom, etc).

9.5 Seat belts

- A. All occupants must utilize six-point, restraint harness meeting the following specifications at all times during practice, qualifying, and the race.
- B. All Harness belts must meet FIA Homologations, FIA 8853/98 or FIA 8853-2016
- C. Installation according to FIA appendix J 253 – ART 6.

9.6 Arm restraints

- A. Competitors may choose to use arm restraints in lieu of windows or a window net.
- B. Competitors with convertible vehicles must use arm restraints.

9.7 Head and neck restraints

- A. A Head and neck restraint certified in accordance with FIA 8858-2002 or 8858-2010 are required at all times on track during practice and competition.

9.8 Extinguishers – extinguishing systems

- A. Fire extinguisher system is recommended
- B. All cars must be fitted with one or two fire extinguishers in compliance with appendix J 253. Articles 7.3.5
- C. Cars running E85 bioethanol fuel – need to be equipped with 4kg manual extinguisher.
- D. All extinguishers must be adequately protected.
- E. Their mountings must be able to withstand a deceleration of 25 g.
- F. Only quick-release metal fastenings (two minimum), with metal straps, are accepted.
- G. Anti-torpedo tabs are required.

